

The following page(s) are extracted from multi-page product catalogues or CDROMs and any page number shown is relevant to the original document. The PDF sheets here may have been combined to provide technical information about the specific product(s) you have selected.

Contact Details

The Encoder Company
H. Kuhnke Ltd
Unit 21, Abbey Enterprise Centre
Premier Way
Romsey
Hants.
SO51 9AQ
UK

T: +44 (0)1794 514445
F: +44 (0)1794 513514
Email: sales@theencodercompany.co.uk

Important Note

The information shown in these documents is for guidance only. No liability is accepted for any errors or omissions. The designer or user is solely responsible for the safe and proper application of the parts, assemblies or equipment described.

Industrial types

Hollow shaft



- Through shaft
- High accuracy by means of integrated flexible coupling
- Safe shaft mounting
- Application e.g.:
 - textile machines
 - motors
 - drives
 - copiers

NUMBER OF PULSES

1 / 2 / 3 / 4 / 5 / 10 / 15 / 20 / 25 / 30 / 35 / 40 / 45 / 50 / 60 / 64 / 70 / 72 / 80 / **100** / 125 / 128 / 144 / 150 / 180 / 200 / **250** / 256 / 300 / 314 / 350 / 360 / 375 / 400 / 460 / 480 / **500** / 512 / 600 / 625 / 720 / 900 / **1000** / **1024** / **1250** / 1500 / 1600 / 1800 / 2000 / 2048 / **2500** / 3000 / 3480 / **3600** / 4000 / **4096** / **5000**

Other number of pulses on request

Preferably available versions are printed in bold type.

TECHNICAL DATA
mechanical

Shaft diameter	10 mm hollow shaft 12 mm hollow shaft
Required dimension of mounting shaft	Ø 10 mm, tolerance g8 (-0.005 ... -0.027 mm) Ø 12 mm, tolerance g8 (-0.006 ... -0.033 mm)
Balance tolerances	
Misalignment axial	± 0.4 mm
Misalignment parallel	0.4 mm
Misalignment angular	1°
Absolute max. speed	max. 3000 min ⁻¹
Torque	≤ Ncm (IP64)
Moment of inertia	approx. 65 gcm ² (10 mm shaft) approx. 95 gcm ² (12 mm shaft)
Protection class (EN 60529)	Housing IP64, bearings IP64
Operating temperature an Welle	-10 ... +70 °C
Storage temperature	-25 ... +85 °C
Vibration resistance (IEC 68-2-6)	10 g = 100 m/s ² (10 ... 2 kHz)
Shock resistance (IEC 68-2-27)	100 g = 1000 m/s ² (6 ms)
Connection	Cable radial, 1.5 m ¹
Housing	Aluminium
Flange	Synchro flange
Weight	approx. 210 g

¹ Other cable length on request

Incremental Shaft Encoders Type RI 58-H

Industrial types Hollow shaft

TECHNICAL DATA electrical

General design	as per DIN VDE 0160, protection class III, contamination level 2, overvoltage class II	
Supply voltage	with RS 422 + Sense (T): DC 5 V ± 10 % with RS 422 + Alarm (R): DC 5 V ± 10 % oder DC 10 - 30 V ¹ with push-pull (K, I): DC 10 - 30 V ¹	
Max. current w/o load	40 mA (DC 5 V), 60 mA (DC 10 V), 30 mA (DC 24 V)	
Standard output versions ²	RS 422 (R):	A, B, N, \bar{A} , \bar{B} , \bar{N} , $\overline{\text{Alarm}}$
	RS 422 (T):	A, B, N, \bar{A} , \bar{B} , \bar{N} , Sense
	push-pull (K):	A, B, N, $\overline{\text{Alarm}}$
	push-pull complementary (I):	A, B, N, \bar{A} , \bar{B} , \bar{N} , $\overline{\text{Alarm}}$

¹ Pole protection with supply voltage DC 10 - 30 V

² Output description and technical data see chapter "Technical basics"

DIMENSIONAL DRAWINGS

Synchro flange

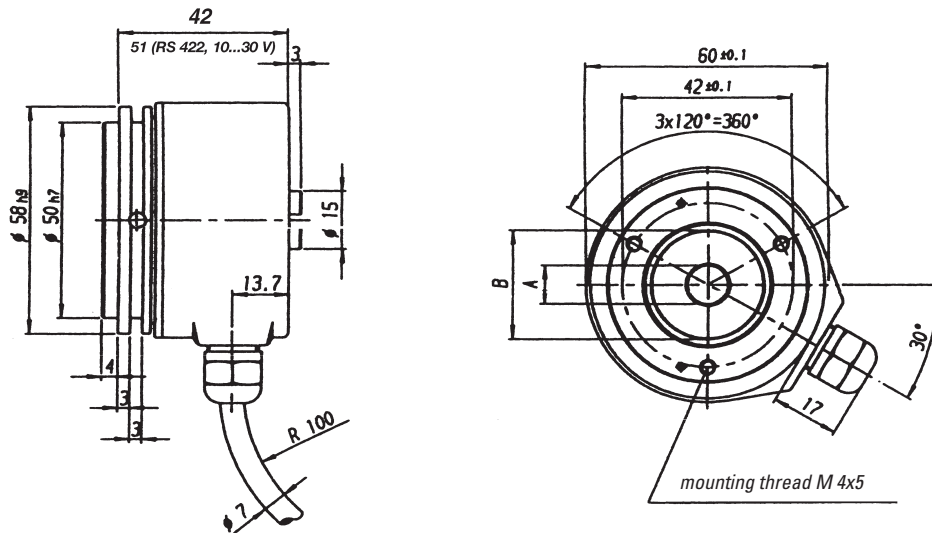

R for alternating bending > 100 mm
R for permanent bending > 40 mm

∅ Hollow shaft	Required dimension of mounting shaft (g8)
10 mm	-0.005 ... -0.027 mm
12 mm	-0.006 ... -0.033 mm

Dimensions in mm

Dim.:	∅	
A	10 mm*	12 mm*
B	28 mm	33 mm

* Tolerance
H7 = 0 ... +0.018 mm

Incremental Shaft Encoders Type RI 58-H

Industrial types Hollow shaft

PIN ASSIGNMENT

Connecting cable		Output	
Colour	Lead \varnothing	RS 422 T and R	push-pull K and I
red	0.5 mm ²	DC 5/10 - 30 V	DC 10 - 30 V
red/yellow	0.14 mm ²	Sense VCC	Sense VCC
white	0.14 mm ²	Channel A	Channel A
white/brown	0.14 mm ²	Channel \bar{A}	Channel \bar{A} ¹
green	0.14 mm ²	Channel B	Channel B
green/brown	0.14 mm ²	Channel \bar{B}	Channel \bar{B} ¹
yellow	0.14 mm ²	Channel N	Channel N
yellow/brown	0.14 mm ²	Channel \bar{N}	Channel \bar{N} ¹
black	0.5 mm ²	GND	GND
black/yellow	0.14 mm ²	Alarm /Sense GND ²	Alarm
screen ³		screen ³	screen ³

¹ only push-pull complementary (I)

² depending on ordering code

³ connected with encoder housing

ORDERING INFORMATION

Type	Model	Number of pulses	Supply voltage	Flange, Protection, Shaft	Output	Connection
<input type="checkbox"/>	<input type="checkbox"/>	<input type="text"/>	<input type="checkbox"/>	<input type="text"/>	<input type="checkbox"/>	<input type="checkbox"/>
RI58-	H Hollow shaft	1 ... 5 000	A DC 5 V ¹ E DC 10 - 30 V ² (only with push-pull)	S.42 Synchro, IP64, 10 mm S.47 Synchro, IP64, 12 mm	K push-pull T RS 422+ Sense R RS 422+ Alarm I push-pull complementary	B PVC cable radial
¹ with output T, R ² with output K, I, R						

ACCESSORIES

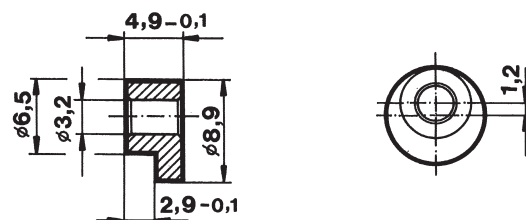

Clamping eccentric (set of tree)
Ordering code 0 070 655

Dimensions in mm

Incremental Hollow Shaft Encoder RI 58-H

Page 2/2

Installation instructions

- All installation work must be performed in accordance with the relevant safety regulations!
- All equipment involved must be electrically disconnected during installation work!
Please ensure that current cannot be applied to this equipment unintentionally during installation.

Preparing for mechanical installation

Before starting the installation, the drive of the *host device* must be prepared to pick up the encoder.

Due to the wide range of drive constructions and installation requirements, only general instructions can be provided; please also refer to the dimensioned drawings of the different encoder versions.

When using an adapter between drive and encoder, the adapter must be designed in a manner that

- the encoder can be mounted safely without being exposed to vibration,
- the encoder can be mounted on the drive before the "B"-side of the drive shaft is secured to the encoder's hollow shaft,
- radial, axial and angular misalignments remain within the specified limits.

Note

- The durability of the integrated coupling largely depends on proper mounting! The coupling must be attached in its neutral position!
Forced compression or extension and/or compensation of an excessive angular or shaft misalignment shorten service life!
- The encoder housing is attached flexibly to the mounting flange.
Subjection to external forces may result in pulse output to the data lines!
Therefore no external forces should be applied to the encoder housing!
- Ensure that the clamping jaw of the hollow shaft is loosened by inserting the drive shaft into the hollow shaft (the clamping jaw is located on the synchro flange side of the encoder).
The shaft must slide easily into the hollow shaft!
Do not use force or try to insert the shaft by hammering on one end!
This would damage the encoder.
- If the shaft cannot be inserted, please check the shaft diameter and/or open the clamping jaw.

Loosening the clamping jaw

(please refer to the following figure and its key)

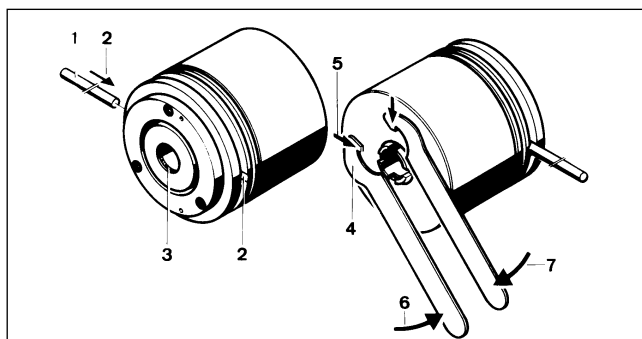

Fig.: Loosening the clamping jaw

Instructions for loosening the clamping jaw

- Insert the retention pin (1) in one of the two holes (2).
- Press the retention pin lightly into the hole and rotate the hollow shaft. After a maximum rotation angle of 180° the retention pin will engage.
- Hold the pin in this position.
- Open the clamping jaw by inserting the hooked wrench (4) in one of the slots of the hollow shaft (5) and rotating the shaft counterclockwise by approx. 1 revolution (6).
This loosens the clamping jaw completely.
- Remove the wrench and the pin.

Mechanical installation instructions

The shaft encoder can be attached to the drive unit in two ways:

- by means of three screws to be screwed into the front end of the encoder
- by means of three clamping eccentrics.

The preparations required for mounting of the drive and the encoder must be complete now.

- Put the encoder on the drive by inserting the actuating end of the drive shaft into the hollow shaft.
- Attach the encoder to the drive by means of the screws resp. the clamping eccentrics.

Securing the drive shaft in the hollow shaft (please refer to the figure)

- Insert the retention pin (1) in one of the two holes (2).
- Press the retention pin lightly into the hole and rotate the hollow shaft. After a maximum rotation angle of 180° the retention pin will engage.
- Hold the pin in this position.
- Tighten the clamping jaw by inserting the hooked wrench (4) in one of the slots of the hollow shaft (5) and rotate the shaft clockwise (7).
This tightens the clamping jaw and clamps the drive shaft.
- Tighten the clamping jaw but moderately:
 - max. tightening torque for shaft 10 mm = 2,5 Nm
 - max. tightening torque for shaft 12 mm = 3,0 Nm.

- Remove the wrench and the pin.

Ensure that no external forces take effect on the encoder during assembly or operation!

Key to the figure

- 1 Retention pin (included)
- 2 Holes for retention pin
- 3 Clamping jaw of the hollow shaft
- 4 Hooked wrench
- 5 Slots in hollow shaft
(for hooked wrench)
- 6 Sense of rotation for loosening the clamping jaw
- 7 Sense of rotation for tightening the clamping jaw



Shaft rotates during operation!