

The following page(s) are extracted from multi-page product catalogues or CDROMs and any page number shown is relevant to the original document. The PDF sheets here may have been combined to provide technical information about the specific product(s) you have selected.

Contact Details

The Encoder Company
H. Kuhnke Ltd
Unit 21, Abbey Enterprise Centre
Premier Way
Romsey
Hants.
SO51 9AQ
UK

T: +44 (0)1794 514445
F: +44 (0)1794 513514
Email: sales@theencodercompany.co.uk

Important Note

The information shown in these documents is for guidance only. No liability is accepted for any errors or omissions. The designer or user is solely responsible for the safe and proper application of the parts, assemblies or equipment described.

Economy Types



- Replacement for type RIM
- Economical miniature encoder
- Up to 14 400 steps with 3 600 pulses
- High mechanical efficiency
- Application e.g.
 - wood working machines
 - FHP motors
 - graphic machines
 - table robots

NUMBER OF PULSES

5 / 10 / 20 / 25 / 28 / 32 / 50 / 60 / 72 / 100 / 128 / 144 / 200 / 250 / 256 / 288 / 300 / 360 / 400 / 500 / 512 / 600 / 720 / 900 / 1000 / 1024 / 1250 / 1500 / 2000 / 2048 / 2500 / 3000 / 3600
 Other number of pulses on request

TECHNICAL DATA
mechanical

Shaft diameter	6 mm
Absolute max. shaft load	radial 10 N, axial 5 N
Absolute max. speed	10 000 min ⁻¹
Torque	≤ 0.2 Ncm
Protection class (EN 60529)	Housing IP50, bearings IP40
Operating temperature	-10 ... +70 °C
Storage temperature	-25 ... +85 °C
Vibration resistance (IEC 68-2-6)	100 m/s ² (10 ... 2000 Hz)
Shock resistance (IEC 68-2-27)	1000 m/s ² (6 ms)
Connection	1.5 m cable, radial ¹
Housing	Aluminium
Flange	Pilot flange
Weight approx.	60 g

¹ Other cable length on request

TECHNICAL DATA
electrical

General design	as per DIN VDE 0160, protection class III, contamination level 2, overvoltage class II
Supply voltage (SELV)	with push-pull (D): DC 5 V ±10 % with push-pull (K): DC 5 V ² ±0 % oder DC 10 - 30 V ²
Max. current w/o load	40 mA (DC 5 V), 60 mA (DC 10 V), 30 mA (DC 24 V)
Standard output versions ³	push-pull (K, D): A, B, N, \overline{A} alarm

² Pole protection

³ Output description and technical data see chapter "Technical basics"

Incremental Shaft Encoders Type RI 41

Economy Types

DIMENSIONAL DRAWINGS

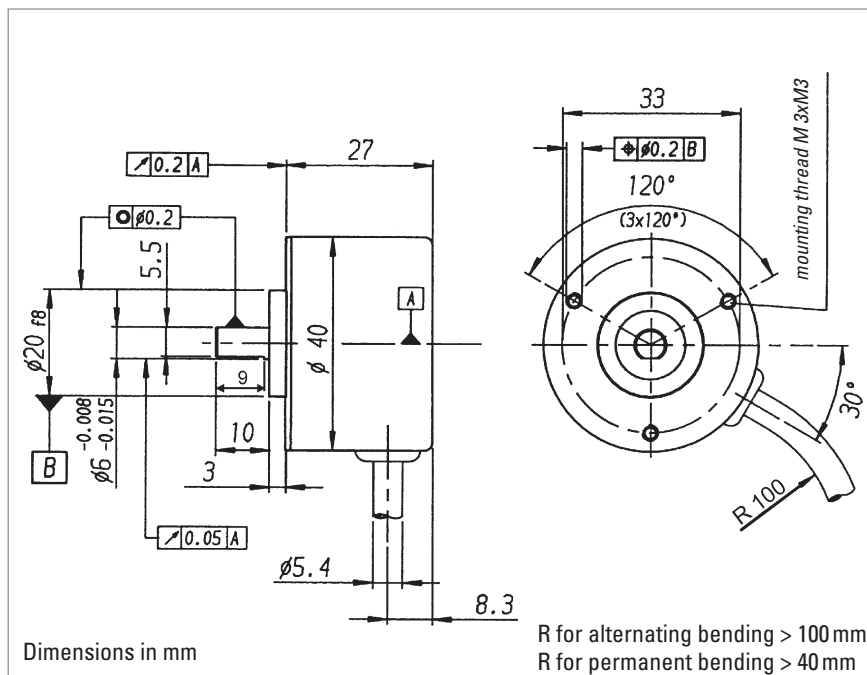

PIN ASSIGNMENT

Description (push-pull)	Lead \varnothing mm ²	Colour
DC 5 V/10 - 30 V	0.5	red
Channel A	0.14	white
Channel B	0.14	green
Channel N	0.14	yellow
GND	0.5	black
Alarm	0.14	yellow/black
screen ¹		screen ¹

¹ not connected with encoder housing

ORDERING INFORMATION

Type	Model	Number of pulses	Supply voltage	Flange, Protection, Shaft	Output	Connection
<input type="checkbox"/>	<input type="checkbox"/>	<input type="text"/>	<input type="checkbox"/>	<input type="text"/>	<input type="checkbox"/>	<input type="checkbox"/>
RI41-	O Standard	5 ... 3600	A DC 5 V E DC 10 - 30 V ¹	R.11 Pilot, IP40, 6 mm	K push-pull ² short circuit proof D push-pull DC 5 V, ± 30 mA	B Cable radial

¹ only with output K
² ± 10 mA at DC 5 V, ± 30 mA at DC 10 - 30 V

Vorwort

Diese Installationsanleitung soll Ihnen den Anschluß und die Inbetriebnahme des Drehgebers ermöglichen. Weitere Informationen finden Sie im Drehgeberkatalog.

Sicherheits- und Betriebshinweise

- Die inkrementalen Drehgeber der Modellreihe RI 36 / RI 41 sind nach den anerkannten Regeln der Elektrotechnik hergestellte Qualitätsprodukte. Die Geräte haben das Herstellerwerk in sicherheitstechnisch einwandfreiem Zustand verlassen. Um diesen Zustand zu erhalten und um einen störungsfreien Betrieb sicherzustellen, sind die technischen Spezifikationen in dieser Dokumentation zu berücksichtigen.
- Einbau und Montage elektrischer Geräte dürfen nur durch eine Elektrofachkraft erfolgen!**
- Die Geräte dürfen nur innerhalb der Grenzwerte betrieben werden, wie sie in den technischen Daten vorgegeben sind.
- Die maximalen Betriebsspannungen dürfen nicht überschritten werden!** Die Geräte sind nach VDE 0160, Schutzklasse III gebaut. Sie müssen zur Verhinderung von gefährlichen Körperströmen mit Sicherheitskleinspannung (SELV) betrieben werden und sich in einem Bereich mit Potentialausgleich befinden.
- Anwendungsbereich: industrielle Prozesse und Steuerungen. Überspannungen an den Anschlußklemmen müssen auf Werte der Überspannungskategorie II begrenzt werden.
- Vermeiden Sie die Einwirkung von Schocks auf das Gehäuse – vor allem auf die Geberwelle – sowie axiale und radiale Überlastungen der Geberwelle.
- Die maximale Genauigkeit und Lebensdauer der Geber wird nur bei Verwendung einer geeigneten Kupplung garantiert.
- Die guten EMV-Werte gelten nur in Verbindung mit den serienmäßig gelieferten Kabeln und Steckern. Bei geschirmten Kabeln ist der Schirm beidseitig und großflächig mit Erde zu verbinden. Auch die Leitungen zur Spannungsversorgung sollten vollständig geschirmt sein. Ist dies nicht möglich, so sind entsprechende Filtermaßnahmen zu ergreifen.
- Die Einbaumgebung und Verkabelung hat maßgeblichen Einfluß auf die EMV des Gebers, so daß vom Installateur die EMV der gesamten Anlage (Gerät) sicherzustellen ist.
- Spannungsspitzen auf der Versorgungsleitung sind durch die vorgeschaltete Spannungsversorgung auf max. 1000 V zu beschränken.
- In elektrostatisch gefährdeten Bereichen ist bei der Installation auf einen guten ESD-Schutz für Stecker und anzuschließendes Kabel zu achten.

Anschlußbenennung der Kabel

		Ausgangsschaltung			
Farbe (TPE)	Farbe (PVC)	RS 422 (T) + Sense	RS 422 (R) + Alarm	Gegentakt (K)	Gegentakt antivalent (I)
braun	weiß	Kanal A	Kanal A	Kanal A	Kanal A
grün	weiß/braun	Kanal \bar{A}	Kanal \bar{A}		Kanal \bar{A}
grau	grün	Kanal B	Kanal B	Kanal B	Kanal B
rosa	grün/braun	Kanal \bar{B}	Kanal \bar{B}		Kanal \bar{B}
rot	gelb	Kanal N	Kanal N	Kanal N	Kanal N
schwarz	gelb/braun	Kanal \bar{N}	Kanal \bar{N}		Kanal \bar{N}
violett (weiß) ²⁾	gelb/schwarz	Sense GND	Alarm	Alarm	Alarm
blau	gelb/rot	Sense V _{CC}	Sense V _{CC}		Sense V _{CC}
braun/grün	rot	5VDC=	5/10...30VDC=	5/10...30VDC=	10...30VDC=
weiß/grün	schwarz	GND	GND	GND	GND

¹⁾ RI 36: mit dem Gebergehäuse verbunden; RI 41: nicht mit Gebergehäuse verbunden

²⁾ weiß bei Ausführung Sense (T)

Bestellschlüssel (siehe Typenschild)

0 Standard	Versorgungsspannung	Flanschart	Wellen-
	A 5 VDC	S Synchroflansch	durchmesser
	E 10 ... 30 VDC	R Rundflansch	1 6 mm
	(nur Gegentakt)		5 6,35 mm

RI 36 - 0 / [] [] [] [] [] [] [] [] *

Strichzahl	Ausgang	Anschlußart ¹⁾ (nur Gegentakt)
5 ... 3600	T RS 422 + Sense	A Kabel axial
	K Gegentakt kurzschlußfest	B Kabel radial
	R RS 422 + Alarm	F TPE-Kabel, radial
1 IP 40	D Gegentakt 5 V, 30 mA	N Binder, 6pol., axial ¹⁾
3 IP 64	I Gegentakt antivalent	J Binder, 6pol., radial ¹⁾

Sonderausführungen sind im Bestellschlüssel zusätzlich mit -S gekennzeichnet. In diesem Fall gelten kundenspezifische Daten. Sollten Ihnen diese nicht bekannt sein, so fordern Sie die Daten bitte unter Angabe der Geber-Sachnummer bei uns an.

Mechanische Daten

Befestigung	Synchroflansch ¹⁾ , Rundflansch ¹⁾
Wellendurchmesser	RI 36: 6 mm/6,35 mm; RI 41: 6 mm
Wellenbelastung	radial 10 N, axial 5 N
Drehzahl	max. 10000 min ⁻¹
Drehmoment	≤ 0,3 Ncm
Schutzart Gehäuse/Kugellager	RI 36: IP 64/64 ²⁾ ; RI 41: IP 50/40
Betriebstemperatur	-10 ... +70 °C
Lagertemperatur	-25 ... +85 °C
Schwingfestigkeit (IEC 68-2-6)	100 m/s ² (10 ... 2000 Hz)
Schockfestigkeit (IEC 68-2-27)	1000 m/s ² (6 ms)
Anschlußart	Kabel oder Flanschdose axial/radial
Gehäuse	Aluminium
Masse	RI 36: 80 g; RI 41: 60 g

¹⁾ Befestigung mit M3-Schrauben
²⁾ stehendes Wasser am Welleneingang oder Kugellager nicht zulässig

Elektrische Daten

Allgemeine Auslegung	gemäß DIN VDE 0160, Schutzklasse III, Verschmutzungsgrad 2, Überspannungskategorie II				
Abschirmung	mit dem Gehäuse verbunden (nur bei RI 36)				
Stromaufnahme	5V/40 mA, 24V/30 mA (10...30V), 10V/60 mA (10...30V)				
Versorgungsspannung U _B	5 V DC (SELV) ±10%		10 ... 30 V DC (SELV)		
Ausgang ¹⁾	GT	GT	RS422	GT	GT antiv.
Kennbuchstabe	K	D	R, T	K	I
Ausgangsbelastung [mA]	±10	±30	±30	±30	±30
Ausgangspegel [V]	High	≥2,5	≥2,5	U _B -3	U _B -3
	Low	≤0,5	≤0,5	≤2	≤2
Schaltzeiten [ns]	250	100	100	2000	2000
max. Impulsfrequenz [kHz]	300	300	300	200	200
Verpolschutz	ja	nein	nein	ja	ja
Kurzschlußfestigkeit	ja	1 Kanal	1 Kanal	ja	ja
Tastverhältnis	1 : 1				
Toleranz	± 25° elektrisch				
Phasenversatz	90° (zwischen Kanal A und B min. 0,45 µs, bei 300 kHz)				
Impulsform	Rechteck				
Alarm-Ausgang	offener Kollektor, NPN (bei U _B =5 VDC max. 5 mA, 24 V; bei U _B =10...30 VDC: max. 5 mA, 32 V)				

¹⁾ GT=Gegentakt; GT antiv.=Gegentakt antivalent; RS422=Line driver

Belegung der Flanschdosen-Pins (nur RI 36)

Binder 6 pol.	
Pin	Gegentakt (K, D)
1	5 V DC= / 10...30 V DC=
2	Kanal A
3	Kanal N
4	Kanal B
5	Alarm
6	GND



0 Standard	Versorgungsspannung	Flanschart	Wellen-
	A 5 VDC	R Rundflansch	durchmesser
	E 10 ... 30 VDC		1 6 mm
	(nur Gegentakt)		

RI 41 - 0 / [] [] [] [] [] [] [] [] *

Strichzahl	Schutzart	Ausgang	Anschlußart
5 ... 3600	1 IP 40	K Gegentakt	B Kabel radial
		K kurzschlußfest	
		D Gegentakt 5V, ± 30 mA	

Technische Änderungen und Verbesserungen, die dem Fortschritt unserer Geräte dienen, behalten wir uns vor.

Introduction

These installation instructions are provided for the connection and starting procedure of your shaft encoders. You can get further informations from our Shaft Encoders Catalogue.

Safety and Operating Instructions

- The incremental shaft encoders of the type RI 36 / RI 41 model series are quality products manufactured in accordance with established electrical engineering standards. The units have been delivered from the factory in perfect conformance to safety regulations.
- To maintain this condition and to ensure trouble-free operation, please observe the technical specifications of this document.
- Installation and mounting may only be performed by an electrotechnical expert!**
- The units may only be operated within the limits specified by the technical data.
- Maximum operating voltages must not be exceeded!**
The units are designed complying with VDE 0160, protection class III. To prevent dangerous structure-borne currents, the equipment has to be run on safety extra-low voltage (SELV) and must be in an area of equipotential bonding.
- Application: Industrial processes and control systems.
Overvoltage at the connecting terminals must be limited to the values within overvoltage category II.
- Please avoid shocks to the housing – especially to the encoder shaft – and axial or radial overload to the encoder shaft.
- Maximum accuracy and durability of our shaft encoders is only granted when using suitable couplings.
- The high-quality EMC-specifications are only valid together with standard-type cables and plugs. When using screened cables, the screen must broadly be connected with ground on both ends. Likewise, the voltage-supply cables should entirely be screened. If this is not possible you will have to take appropriate filtering measures.
- Installation environment and wiring are influential on the encoder's EMC: Thus the installer must secure EMC of the whole facility (device).
- Transient peaks on the power supply leads are to be limited by the preconnected power unit to a maximum of 1000 V.
- In electrostatically threatened areas please take care for neat ESD-protection of plug and connecting cable during installation work.
- Specified maximum shaft loads are only given under restrictions:
 - Full bearing life of 1×10^{10} revolutions (typ.) will be reached at 35% of full rated shaft load
 - a bearing life of 1×10^8 revolutions (typ.) will be reached at 100% of full rated shaft load.
- For use in class II circuits only

Connection diagram

		Output circuit			
Colour (TPE)	Colour (PVC)	RS 422 (T) + Sense	RS 422 (R) + Alarm	Push-pull (K)	Push-pull complem. (I)
brown	white	Channel A	Channel A	Channel A	Channel A
green	white/brown	Channel \bar{A}	Channel \bar{A}		Channel \bar{A}
grey	green	Channel B	Channel B	Channel B	Channel B
pink	green/brown	Channel \bar{B}	Channel \bar{B}		Channel \bar{B}
red	yellow	Channel N	Channel N	Channel N	Channel N
black	yellow/brown	Channel \bar{N}	Channel \bar{N}		Channel \bar{N}
violet (white) ²⁾	yellow/black	Sense GND	\bar{A} Alarm	Alarm	\bar{A} Alarm
blue	yellow/red	Sense V_{CC}	Sense V_{CC}		Sense V_{CC}
brown/green red		5VDC=	5/10...30VDC=	5/10...30VDC=	10...30VDC=
white/green black		GND	GND	GND	GND
Screen ¹⁾	Screen ¹⁾	Screen ¹⁾	Screen ¹⁾	Screen ¹⁾	Screen ¹⁾

¹⁾ RI 36: connected to encoder housing; RI 41: not connected to encoder housing

²⁾ white for Sense (T)

Ordering data (see identification plate)

0 Standard	Supply voltage A 5 VDC E 10 ... 30VDC (Push-pull only)	Type of flange S Synchro flange R Round flange	Shaft diameter 1 6 mm 5 6.35 mm
R I 3 6 - 0 /			
Number of pulses 5 ... 3,600	Output T RS 422 + Sense K Push-pull short circuit proof R RS 422 + Alarm	Type of connection (¹⁾ push-pull only A Cable axial B Cable radial N BINDER, 6 pin, axial ¹⁾ J BINDER, 6 pin, radial ¹⁾	
Protection class 1 IP 40 3 IP 64	D Push-pull 5 V, 30 mA I Push-pull complementary		

* Special types are additionally marked by an ordering code -S. In this case customer specifications are to be applied. If you don't know these please call us for the specifications, indicating the encoder ordering code.

Mechanical data

Mounting	synchro flange ¹⁾ , round flange ¹⁾
Shaft diameter	RI 36: 6 mm/6.35 mm; RI 41: 6 mm
Absolute max. shaft load	radial 30 N (6.5 lbs), axial 15 N (3.3 lbs)
Max. speed	10,000 RPM
Torque	≤ 0.3 Ncm
Protection class housing/ball bearing	RI 36: IP 64/64 ²⁾ ; RI 41: IP 50/40
Operating temperature	-10 ... +70 °C
Storage temperature	-25 ... +85 °C
Vibration performance (IEC 68-2-6)	100 m/s ² (10 ... 2,000 Hz)
Shock resistance (IEC 68-2-27)	1,000 m/s ² (6 ms)
Connection	cable or flange box axial/radial
Housing	aluminium
Weight	RI 36: 80 g; RI 41: 60 g

¹⁾ use threads M3 for fastening

²⁾ no standing water allowed at the shaft entrance or at the ball bearing

Electrical data

General design	as per DIN VDE 0160, protection class III, contamination level 2, overvoltage class II				
Screening	connected to housing (RI 36 only)				
Power consumption	40 mA (5 V DC), 30 mA (24 V DC), 60 mA (10 V DC)				
Supply voltage U_B	5 V DC (SELV) ±10%		10 ... 30 V DC (SELV)		
Output circuit ¹⁾	PP	PP	RS422	PP	PP compl.
Code letter	K	D	R, T	K	I
Output load [mA]	±10	±30	±30	±30	±30
Output level [V]	High	≥2.5	≥2.5	≥2.5	$U_B - 3$
	Low	≤0.5	≤0.5	≤0.5	≤2
Pulse rise time [ns]	250	100	100	2000	2000
Max. pulse frequency [kHz]	300	300	300	200	200
Pole protection of U_B	yes	no	no	yes	yes
Short circuit proof	yes	1 channel	1 channel	yes	yes
Pulse duty factor	1 : 1				
Pulse width error	± 25° electrical				
Phase shift	90° (distance from Channel A to B is at least 0.45 µs, at 300 kHz)				
Pulse shape	rectangular				
Alarm output	Open Collector, NPN (5 mA, 24 V max with $U_B = 5VDC$; 5 mA, 32 V max. with $U_B = 10...30VDC$)				

¹⁾ PP=Push-pull; PP compl.=Push-pull complementary; RS422=Line driver

Pinout of flange box (RI 36 only)

		Binder 6 poles
Pin		Push-pull (K, D)
1		5 V DC= / 10...30 V DC=
2		Channel A
3		Channel N
4		Channel B
5		Alarm
6		GND

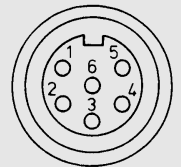

0 Standard	Supply voltage A 5 VDC E 10 ... 30VDC (Push-pull only)	Type of flange R Round flange	Shaft diameter 1 6 mm
R I 4 1 - 0 /			
Number of pulses 5 ... 3,600	Protection class 1 IP 40	Output K Push-pull short circuit proof D Push-pull 5 V, ± 30 mA	Type of connection B Cable radial